

Dock Planning 101



LODEM

LOADING DOCK EQUIPMENT MANUFACTURERS

A Product Section of Material Handling Industry, MHI



Table of Contents

Introduction to Dock Planning	3
Glossary of Terms	4
Trailer Configurations	9
Dock Approach	10
On-Site Traffic Flow	11
Apron Space	12
Dock Positioning	13
Dock Height & Door Dimensions	15
Dock Levelers	18
Vehicle Restraints	23
Dock Seals and Shelters	26
Publication Contact Information	35

What You Always Wanted to Know About Dock Planning But Were Afraid to Ask

Just what the heck is involved with dock design?

In the competitive world of logistics, facilities need to be safe, versatile and efficient in overall design. A properly designed dock area can be a huge contributor in productivity or a complete bottleneck for material flow if not given the time it deserves. This guide was created to assist in the basic design of the loading dock and introduce the reader to fundamental concepts of dock design. It is recommended you combine the information contained here with the help of a seasoned professional and/or your local provider of loading dock equipment for mor complete solution.

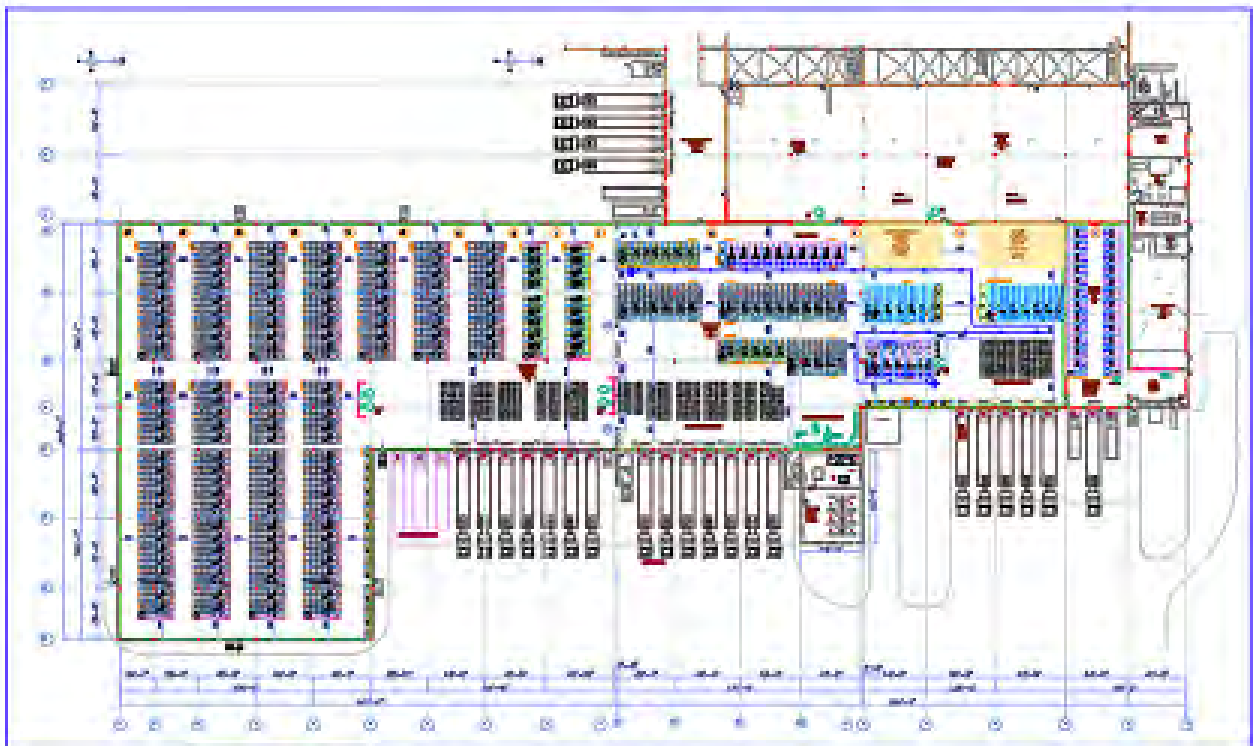

Common Terms and Definitions

Activation System: The activation system provides the motive power of the dock leveler. These systems may or may not require external power interfaces. Typical activation systems are mechanical (springs), pneumatic (air bladders) and hydraulic.

Attachments: This term refers to implements that can be added to a fork truck for handling a load. Attachments such as clamps, slip sheet forks and carpet poles can have an effect on capacity and should be considered in selecting a dock leveler.

Automatic Operation: placement of a vehicle restraint device in its operating position by powered means not initiated by the loading dock operating personnel.

Barrier: the portion of a vehicle restraint device that engages the transport vehicle to prevent movement.

Bumpers: These are used to prevent the transport vehicle from contacting and damaging the building, dock leveler or vehicle restraint. They are usually made of rubber. Bumper sizes and projections vary, based on vehicles serviced and other factors such as driveway slope.

Capacity: The manufacturer's capacity tag rating may not reflect the gross roll-over load for a specific dock leveler. Capacity is the rating of the load that the manufacturer of the dock leveler deems to be appropriate for the design, based on considerations of the characteristics of the user's application. The required capacity of a dock leveler for a specific application is usually determined by taking the GVW and applying a complexity factor to it. The complexity factor is typically determined by a set of characteristics that are present at the particular application. These characteristics may include, but are not limited to: the heaviest fork lift and load (GVW) being driven across the dock leveler; the number of fork lift cycles driving across the dock leveler; the speed of fork lift moving across the dock leveler; the life expectation of the dock leveler; the loading slope above or below dock level; the use of three vs four wheel lift trucks; whether there are attachments on the front end of the lift truck; the lip length as well as other considerations. The authorized sales representative of the manufacturer can help determine the capacity of the dock leveler that is required for a specific application.

Communication Lights: colored lights to communicate the status of the loading operation to the dock operator and to the driver of the transport vehicle. Typically one set of lights is visible to the dock operator to indicate whether the restraint is engaged, and another set of lights is visible to the transport vehicle driver to indicate whether it is safe to pull the vehicle away from the dock. The lights are typically green to indicate "GO" and red to indicate "STOP". Amber lights may be used to indicate caution.



Common Terms and Definitions

Deck: The deck assembly is the major part of the structure that is driven over. Most decks have some type of anti-skid surface such as a tread plate surface to provide traction at the various working angles. The deck assembly pivots at the back end of the dock leveler - the end of the dock leveler that is furthest from the transport vehicle. The dock leveler has a hinged lip attached to the other end.

Dock: This is the area of a building where loading and/or unloading of transport vehicles takes place.

Dock Face: Vertical surface at the front of a dock projecting from the driveway to the dock floor.

Dock Height: Dimension from dock floor down to the top of the drive approach or to top of rail in the case of rail sidings.

Dock Level: This term involves the vertical level that conforms to the building's floor surface.

Dock Leveler: a device affixed to a dock structure to form a bridge between the dock structure and a transport vehicle, thus allowing movement of industrial vehicles between the transport vehicle and the dock structure.

Dock Pit: The pit is the recessed opening in the building's floor that accommodates the pit dock leveler. Most pits are lined along the edges with structural steel angles that are embedded in the concrete.

Dock Mounted Restraint: a vehicle restraint mounted to the dock structure, usually the face of the dock.

Dock Seal: Foam filled side pads bonded to a rigid frame and encapsulated with a fabric covering. Dock seals have several variations of head pads and curtains to accommodate different door and trailer sizes.

Dock Shelter: An enclosure which projects from the face of the building that has head and side curtains that extend toward the opening's width and height in order for the curtains to contact the vehicle body to create a seal. The projecting frames can be either rigid or flexible, spring activated.

Dock Types, Common:

Cantilever Dock: When a concrete dock ledge at floor level extends beyond the foundation and building walls.

Flush Dock: Building wall and foundation wall are flush.

Extended Foundation: When foundation wall extends beyond the building wall from dock floor down to drive approach.

Common Terms and Definitions

Driveway: the surface in front of the dock where the transport vehicle is parked. The driveway surface may be generally horizontal or may be sloped toward or away from the dock. The driveway surface is typically made of concrete, asphalt or gravel.

Drive Approach Types:

Level Drive: When the drive is flat and parallel to the building floor

Declined or Depressed Drive: (ie. Water would run toward the building) This condition frequently incorporates a trench drain near the foundation wall.

Inclined Drive: (ie. Water would run away from the building)

NOTE: An inclined or declined drive approach may require the dock seal or shelter be tapered from top to bottom. The amount of taper will be dependent on degree of the incline or decline.

Driveway Mounted Restraint: a vehicle restraint mounted to the driveway surface rather than to the dock.

Frame: The frame assembly is the supporting structure for a dock leveler.

Gross Vehicle Weight (GVW): The GVW is the combined weight of the material handling equipment (lift truck, pallet jack, etc) and the load. In other words, it is the total maximum weight moving across the dock leveler.

Horizontal Operating Range: range of height of the RIG measured from the driveway that can be engaged by the restraint. The horizontal distance between the face of the dock bumpers and the restraining surface of a vehicle restraint. See “working range”

ICC Bar: see “rear impact guard (RIG)”

Industrial Vehicle: fork lift trucks, powered or non-powered pallet jacks, or any other form of vehicles used to load or unload material on a transport vehicle.

Light Communication Package: typically a red and green light system which can be activated manually or automatically. Intended to improve communication between loading dock operating personnel and transport vehicle driver.

Lip: The lip assembly is usually pivotally attached to the deck assembly and pivots from a vertical stored position to a position that rests on the transport vehicle’s floor. Lips are usually made with a tread plate that is similar to the deck.



Common Terms and Definitions

Load: The load is the weight of a typical individual pallet on a transport vehicle. For typical capacity calculations there are a maximum of (20) twenty loads per transport vehicle.

Loading Dock: building area or structure where goods are moved to and from a transport vehicle. The dock is usually elevated above a driveway where the transport vehicle is parked.

Loading Dock Operating Personnel: a person or persons engaging in the process of loading and/or unloading transport vehicles whereby the activities may include the operation of industrial vehicles, dock levelers, vehicle restraints, dock doors, etc.

Manual Operation: placement of a vehicle restraint device in its operating position by the manual effort of the loading dock operating personnel.

Opening Size: The door opening size is determined at the outside face of wall where shelter/seal will be mounted. The two opening sizes to consider are “door opening” and “seal opening” size.

A) Door Opening Size - Distance between door jamb

B) Seal Opening Size - Inside dimension of dock seal side pads

The selection of the appropriate opening size should be determined by the type and size of vehicles to be serviced and the type of material handling operation in place at a particular facility.

(RIG) Rear Impact Guard: a structure attached to the rear of a transport vehicle to prevent an automobile from running under a transport vehicle during a rear end collision (a.k.a. ICC bar or underride guard). As of January 1998, U.S. federal motor vehicle safety standards FMVSS 223 & FMVSS 224 regulate the performance and use of rear impact guards for trailers rated over 10,000 pounds Gross Vehicle Weight (GVW).

RIG Bar Restraint: a vehicle restraint that engages the rear impact guard (RIG) of a transport vehicle, thus preventing movement of the vehicle away from the dock structure.

Shift: This term refers to the working shift at the building. For capacity calculation purposes, a typical capacity calculation would involve a maximum of (8) eight trailers per shift.

Shim: These are steel plates that maybe used to help level pit-mounted dock levelers. Shims may be placed under the frame structure and would be welded in place in order to provide a structural load path to the building's foundation.

Toe Guard: It is a shield that is mounted flush to the side of a deck assembly in order to provide toe protection when the dock leveler is above dock level.

Common Terms and Definitions

Transport Vehicle: A cargo-carrying vehicle (e.g., a truck, semi-trailer, trailer, or railcar) which may be entered upon by a powered or non-powered industrial vehicle or conveyors to load or unload material.

Underride Guard: See “rear impact guard”

Unscheduled Departure: the event of a transport vehicle departing the dock before loading or unloading is completed.

Vehicle Creep: the movement of a transport vehicle away from the loading dock caused by the transfer of momentum as an industrial vehicle decelerates when entering the vehicle and accelerates when exiting the vehicle. Uncontrolled trailer creep may allow the lip of a dock leveler to become unsupported and create a dangerous gap between the transport vehicle and the dock.

Vehicle Restraining Device: a device affixed to a dock structure or a driveway to engage a transport vehicle.

Vertical Operating Range: the range of heights of the bottom of an RIG above the driveway that can be engaged by the vehicle restraint. See “working range”

Wheel Chock: a block, usually wedge shaped, which is placed on the driveway in front of a wheel of a transport vehicle to inhibit movement of the vehicle away from a loading dock.

Wheel Restraint: a vehicle restraint that engages one or more wheels of a transport vehicle, restraining uncontrolled movement of the vehicle away from the dock structure.

Working Range: the horizontal and vertical range of positions of an RIG that can be engaged by the vehicle restraint.

Yard Jockey: Spotter vehicles or yard jockeys are used at larger shipping facilities to position trailers at dock openings.

Trailer Configurations

Designing the dock area requires the consideration of the following variables:

- 1) Trailer configurations
- 2) Dock approach
- 3) Apron space
- 4) Dock positioning
- 5) Dock height
- 6) Door size.

TRAILER CONFIGURATIONS

Truck Bed Height

A typical loading dock may at some point service every type of vehicle on the road. It is essential to recognize the characteristics of the trailers that will be visiting the loading dock with the highest frequency. This determines the most appropriate design for the dock itself. Secondary consideration must be given to vehicles that visit the dock with less frequency. If it is a captive fleet (only one style of trailer) being serviced at the facility, then the choice of design is simple. However, due to the range of vehicles utilized by freight companies and product suppliers, it is vital to consider all of the possible variations that can occur.

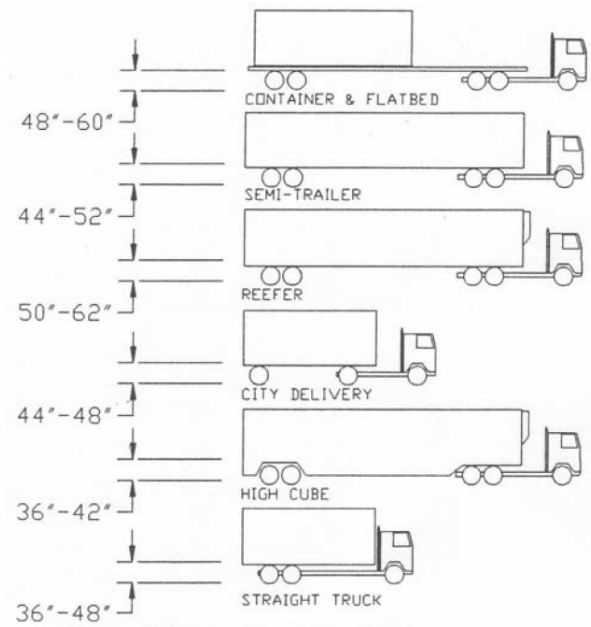

	TRUCK BED HEIGHT TOTAL RANGE		OVERALL ALL TRUCK HEIGHT TOTAL RANGE	
	MIN	MAX	MIN	MAX
CONTAINER	56"	62"	12'-2"	13'-6"
REEFER	50"	62"	12'-6"	13'-6"
DOUBLE AXLE SEMI-TRAILER	44"	52"	12'-0"	13'-6"
CITY DELIVERY	44"	48"	11'-0"	12'-6"
HIGH CUBE VAN	36"	42"	13'-0"	13'-6"
FURNITURE VAN	24"	36"	13'-0"	13'-6"
STEP VAN	20"	30"	8'-6"	10'-0"
PANEL TRUCK	20"	24"	8'-0"	9'-0"
STRAIGHT TRUCK	36"	48"	10'-6"	12'-0"
FLATBEDS	48"	60"	-	-
SPECIAL				

Dock Approach

Dock Approach Types

The grade of a driveway determines how a spotted trailer is orientated to the building wall. On a level approach, the gap between the trailer and the wall remains the same from top to bottom. An incline approach will position a trailer farther from the building wall at the top than at the bottom. On a decline approach the trailer is closer to the building wall at the top.

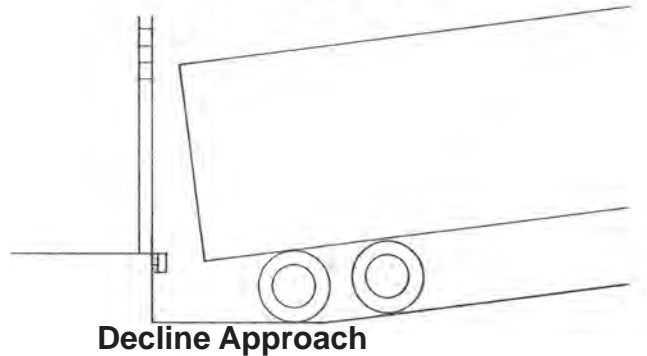
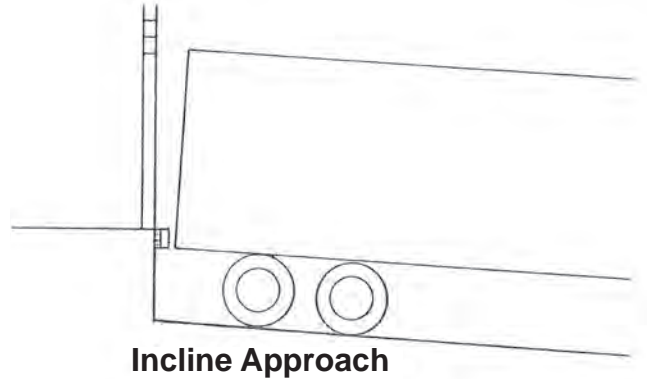

The required projection is calculated based on the grade percentage. To calculate the grade, determine the difference in height between the dock and a fixed point approximately 50' directly out from the dock. Grade equals the height difference divided by the length measured.

Example: 22 in. difference over 660 in. distance
 $22 \div 660 = 0.03$
 $0.03 \times 100 = 3\%$ grade

Declined approaches should not exceed a 10% grade for proper and efficient dock operations.

Use the following chart to select the proper dock projection.

Pit Projection for Decline Drive							
Percent of Driveway Grade	0%	1%	2%	3%	4%	5%	..10%
Pit Projection	0"	2"	3"	4"	5"	6"	.. 12"

$$\text{Percentage of Grade} = \frac{\text{Rise of Driveway}}{\text{Driveway Length}}$$

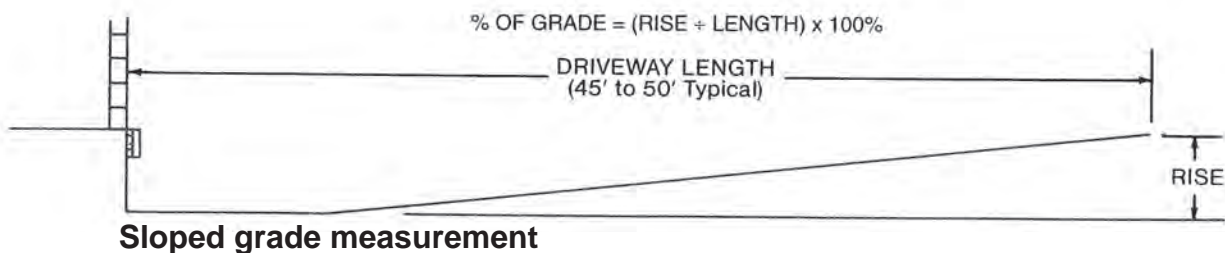

Planning On-Site Traffic Flow

Planning On-Site Traffic Flow

The truck driver has a better view of and control of a truck when sitting on the inside of the turn. So, plan traffic flow around the facility that places the truck driver on the inside of each turn. Where the driver sits on the left side of the truck cab—in countries with right side road traffic—plan for counter-clockwise truck movement around the building.

For efficient on-site truck traffic, include the following elements in your design:

- An entrance driveway that is large enough to handle the turning radius of the longest truck serving the site. For efficiency and safety, permit trucks to be driven forward onto plant property, rather than backed up.
- Right angle turns onto the site that has a minimum inside radius of 26' and a minimum outside radius of 50'.
- One-way access roads that are at least 13' wide and two-way roads that are at least 26' wide.
- Employee roadways that are separate from truck traffic.
- Truck waiting areas adjacent to the loading docks. Unless you design the loading docks for peak arrival traffic, the waiting area has to accommodate all waiting trucks.

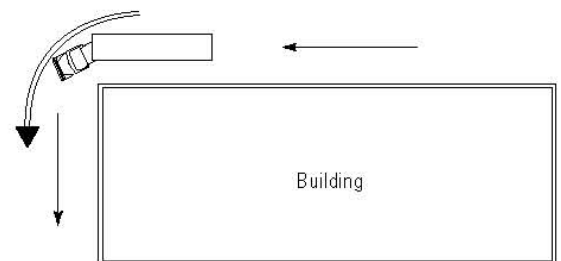
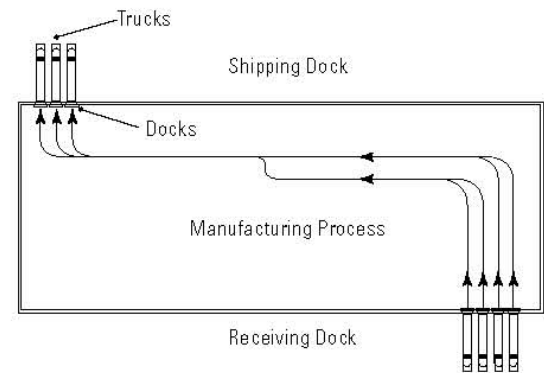
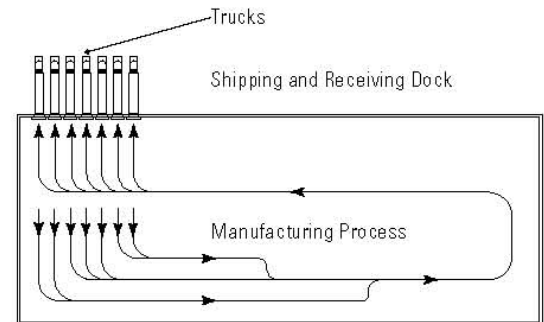

Designing Apron Space

Designing Apron Space

The Apron Space is the space between the loading platform and the fence line or nearest obstruction. It includes the parking area, where the truck is parked during loading, and the maneuvering area; the space needed to maneuver the truck in and out of the parking area. The minimum recommended center distance between the dock positions is 12'.

The minimum apron space needed depends on the:

- Center line distances between the parked trucks at the dock.
- Length of the trucks
- Steering geometry of the trucks.

Note if the trailers will be parked with the tractors detached, less apron space is needed.

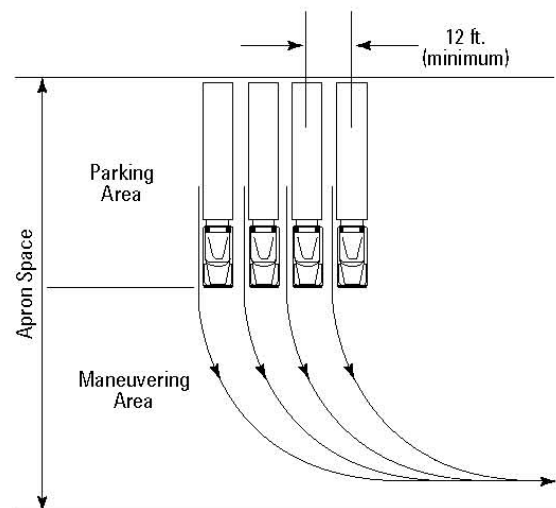
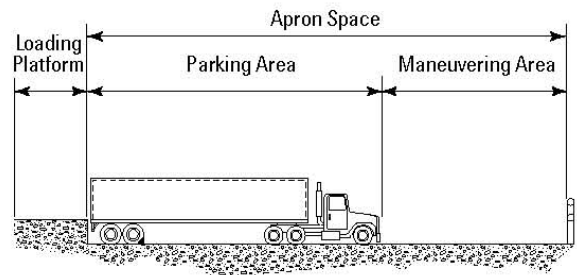
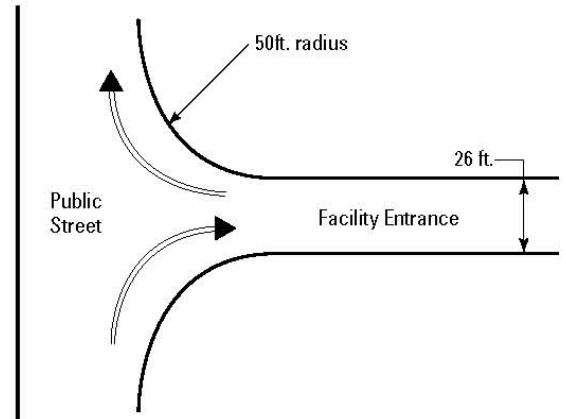

Dock Positioning

Selecting Loading Dock Configuration

Dock positioning involves the physical layout of the dock doors and levelers. The most common dock arrangement is a flush wall with doors spaced on at least 12' centers. If special trailers frequent the facility, door spacing may need to be increased. Twelve-foot centers allow for an overall truck width of 10' including side mirrors. Narrower spacing is possible when room is limited. When incorporating narrower centers, give consideration to common member dock seals and shelters.

Inside/Outside Dock

This common design places the loading platform inside the building, while the trailer remains outside. With the proper door seals or shelter, the design offers excellent weather protection and security. A common variation of the inside/outside dock is the refrigerated dock. The inside/outside dock design sometimes requires that you set back the building wall from the edge of the dock. This is the case particularly for docks with recessed parking areas. The setback is needed to:

- Protect the wall from being hit by trucks
- Protect building projections, such as overhangs or signs
- Facilitate the installation of door seals
- Minimize the risk of injury

Allow at least an 8" clearance between the rear of the truck and the building wall, measured at a height of 6' above the dock platform. Also allow at least 6" of clearance between the top of the trailer and the building wall.

For refrigerated docks include a vestibule between the loading platform and the refrigerated area. The vestibule creates an air lock between the outside and the refrigerated area. The air lock minimizes the inflow of warm air and humidity. A well designed refrigerated dock reduces refrigeration power consumption by 50% or more and it reduces refrigerant coil defrosting by as much as 96%, compared to an open loading dock.

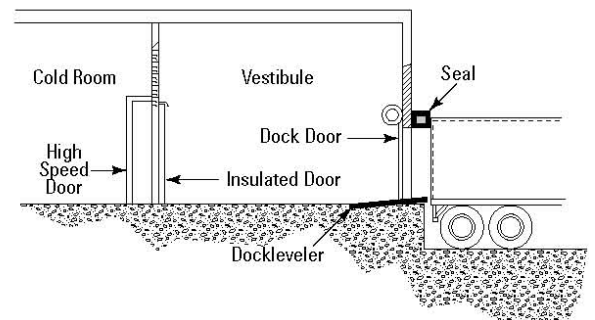
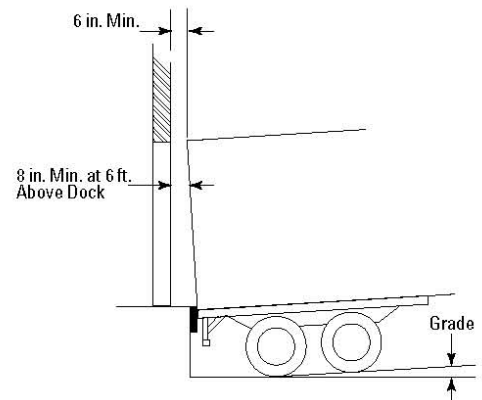
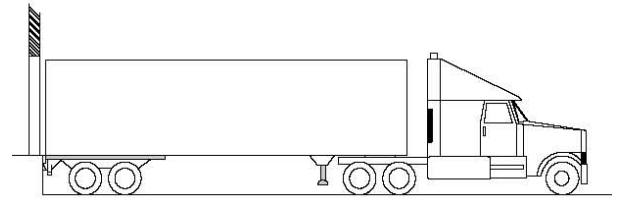

Dock Positioning

Open Dock

This design places both the loading platform and the trailer outside the building. Outside docks are commonly used for general warehousing in temperate and warm climates.

The outside dock requires sufficient forklift maneuvering space between building wall and the dock levelers. Also, you must add concrete posts and safety chains, or other barriers, to reduce the risk of forklifts driving off the dock.

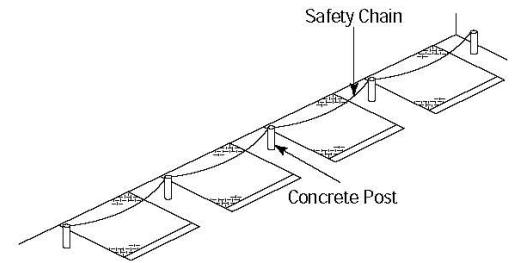
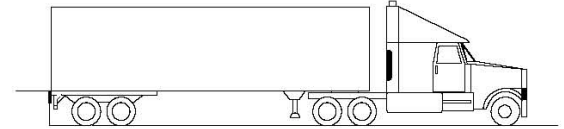

Additional Loading Dock Configuration

Building and property limitations sometime require the use of still other loading dock configurations.

Saw-Tooth Dock

Where space is limited for vehicle positioning, a saw tooth dock arrangement may offer the solution. The building wall is generally set back leaving the dock open and unsheltered from the outside environment. For that reason, a canopy should be utilized to offer worker and product protection. One disadvantage of sawtooth docks is the amount of internal floor space taken up.

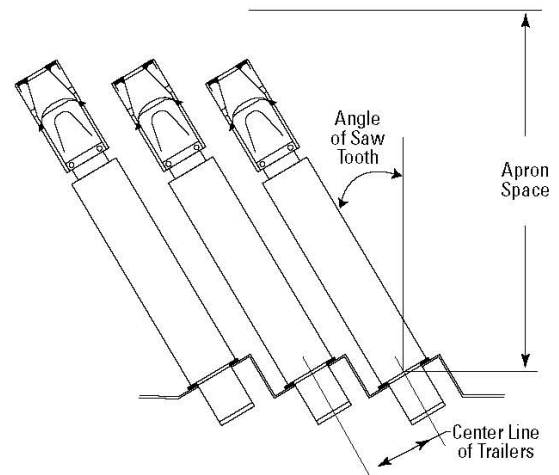

Dock Height

Setting the Dock Height

The most important characteristic of the loading dock design is the height of the dock. The dock height must match the height of the docking trucks. The height difference between the dock and the trailer bed should be as small as possible. The dock leveler bridges some height difference, but the incline should not be too steep. A steep incline can cause insufficient forklift under clearance, and it increases maintenance demands on the equipment.

To determine the dock height, find the midpoint of the bed heights of the expected trucks. Most trucks require a dock height of between 46 and 52 in.

Type of Truck	Dock Height
Container	55 in.
Semitrailer	48 in.
Straight Truck	44 in.
Refrigerated	52 in.
Flatbed	52 in.

NOTE: Truck beds will rise and lower during loading and unloading.

Dock Door Dimensions

DOOR SIZES

Selecting the proper door size is essential when planning the loading dock. Improperly sized doors can create logistic headaches, reduced efficiency, and product damage. Consideration must be given to both the variety of trailers that will visit the dock and the loading method of the product. Planning now for possible future changes can save time, money, and frustration.

Door Width

The majority of trucks on the road today are at least 8' wide, and an increasing number are 8'6" wide. An 8' door width can service these trucks, but maneuvering room is limited. Another concern of 8' door widths is off-center truck positioning. This can lead to further reductions in efficiency and even create the need for repositioning of the vehicle.

Ideally, nine-foot wide doors should be used to service 8'6" wide trailers. Side-by-side palletizing is simplified and the potential for product damage is significantly reduced. Nine-foot wide doors can also accommodate the unplanned servicing of many oversized loads.

For special applications with oversized loads, a 10' wide door can be incorporated.

Wider doors require more building space which can create a problem when room is restricted. Keep in mind the maximum overall limits for trailer size are 8'-6" wide x 13'-6" high (different in some states). Flat bed carriers are able to exceed the maximum width dimensions (special permits are required).

Door should be spaced on a minimum of 12' centers to accommodate the majority of vehicles, the use of dock seals / shelters, and the mounting of two-way communication light systems provides justification to increase truck center lines to 14'. Center lines of 14' or even greater are common in today's loading dock environment.

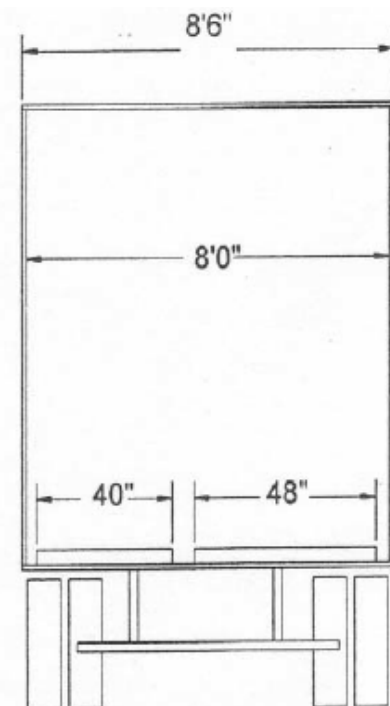
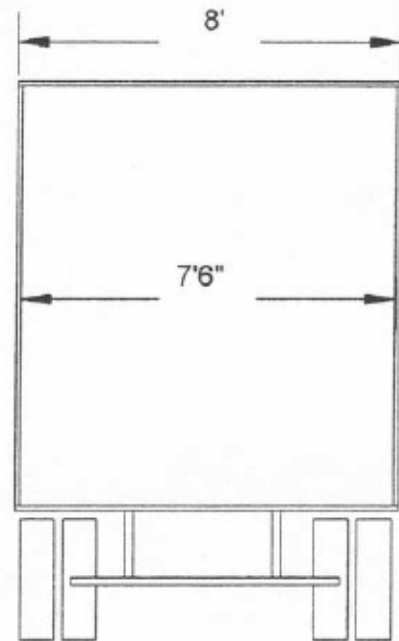

Dock Door Dimensions

DOOR HEIGHTS

Trailers can range in height from flatbed units (approximately 48") to closed vans (162" from ground level). The highest internal height for product loading is approximately 114" high. Depending on the application, there are three basic door heights that are typically specified. Keep in mind that the common dock height is 48" - 52".

Eight foot (96") high doors can accommodate many loading/unloading operations, but do not facilitate full floor to ceiling loading of product. The need to optimize the available height in a trailer when loading product in an effort to minimize freight costs, this need makes the 8' high door a less desirable choice.

A nine foot (108") high door permits improved floor to ceiling loading of product because a higher load can easily pass under the door opening. Fuller and tighter loading is possible with a reduced risk of product damage due to product impact with the door header. The nine foot height is a popular door height because it suits a wide range of applications. However, trailers with lower heights may create a gap at the top of a 9' door. This gap can be sealed with an appropriately sized dock seal or shelter.

A third typical door height is ten feet (120").

The most versatile door size is 10' (120") high. This height will service the full range of loading / unloading operations. Ten foot high doors will accommodate trailers of all heights up to and including high cube trailers and high cube sea containers.

Special consideration should be given when choosing a dock seal or shelter for a 10' high door. A dock shelter with a 10' high door provides the greatest degree of unobstructed access to the rear of the trailer. Door sizes can be specified to any configuration required. Keep in mind the product characteristics and possibility of future change.

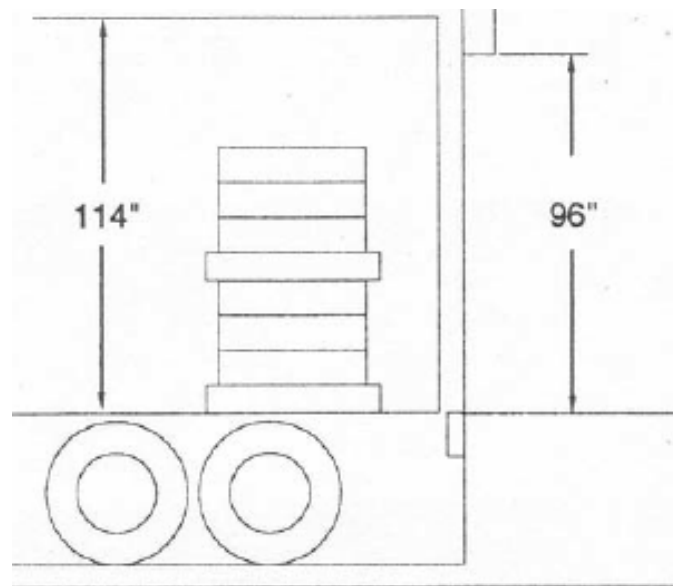

Eight foot (96") high doors can accommodate many loading operations when loading operations where height is not critical to product arrangement.

Improved space utilization and reduced product damage result with ninefoot (108") high doors.

Dock Levelers

Selecting Dock levelers

A dock leveler bridges the gap and height difference between the dock and the trailer. It also compensates for the up and down float of the trailer bed during loading & unloading. A dock leveler includes a ramp (hinged along its rear edge) and a lip (hinged at the front of the ramp). When not in use, the dock leveler is stored in its neutral position, flush with the loading platform floor. To use a dock leveler, the operator raises the ramp and the lip swings out. With the lip full extended, the operator lowers the ramp until the lip rests on the truck bed.

Comparing the Dock Leveler Types

The two common types of dock levelers are:

- A pit style type, installed in a pit formed in the loading platform.
- An edge-of-dock type, installed on the curb of the loading platform

Pit Style Dock Levelers

The pit style dock leveler is the most common type and has the greater operating range above and below dock. It also has the greater load range and longer life expectancy. It is available in ramp lengths or 6' to 12'.

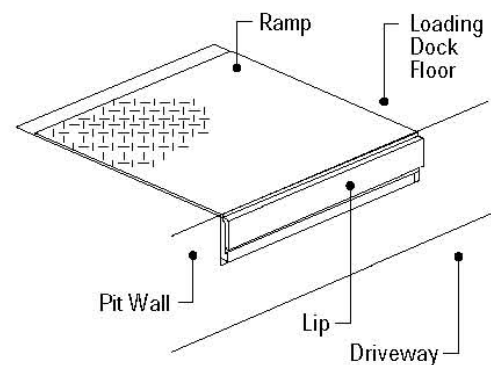

Edge-of-Dock Levelers

The Edge-of-Dock (EOD) dock leveler is a low cost alternative. It is suited for a small range of applications where there is little variation in truck bed height and where pallet truck under clearance is not an issue. Because of its short ramp, the EOD is restricted to a narrow service range 5" above or below the dock.

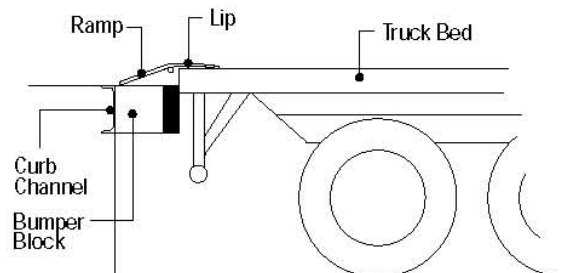

Dock Levelers

Pit style dock levelers are available in powered, push-button operation or spring-loaded mechanical operation. Powered push-button models are easier to operate

Depending on ramp length, pit style dock levelers can serve trailers as much as 18" above and below the dock. A common range is 12" above and 12" below dock height.

Hydraulic Pit Leveler This is the most versatile of the pit style levelers. A hydraulic cylinder is used to raise and to lower the deck, while another is typically used to operate the lip. These levelers may come in various configurations and may be powered by everything from 110V single phase to 575V three-phase.

The hydraulic option gives you more versatility than either mechanical or air dock levelers and typically would have lower service and maintenance costs.

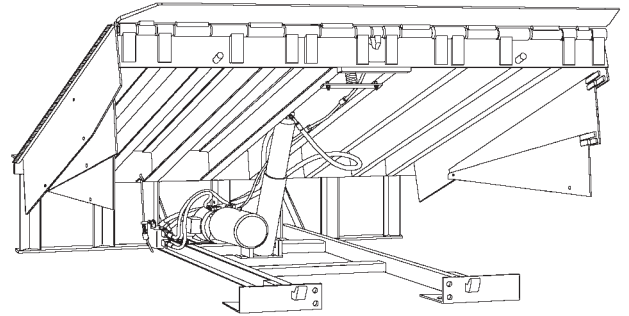

Hydraulic Dock Leveler

Air Pit Leveler This type uses a pneumatic bag system of some type to raise and lower the leveler deck. Obviously, this leveler requires some type of electrical power source - either at the dock or adjacent to it. Most typically, this power source would be standard 110v power. Generally, these levelers are moderately more expensive than mechanical levelers but can involve reduced service and maintenance requirements when compared to mechanical units.

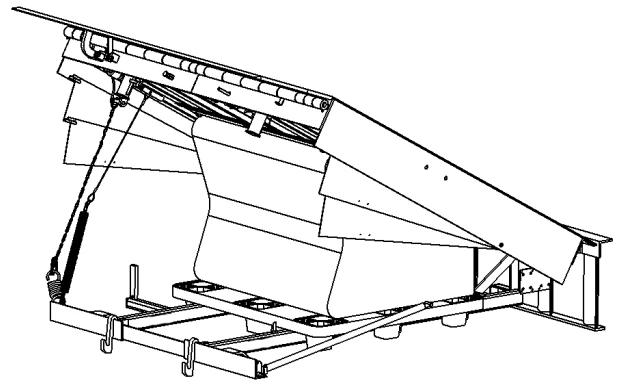

Airbag Dock Leveler

Mechanical Pit Leveler This is the most common of the pit leveler category and typically the least expensive. This leveler style uses a mechanical spring system to raise the leveler and is typically "upward biased." This means that the spring is tending to force the leveler deck to rise up all of the time and a restraining device is preventing that motion. No electrical power supply at the dock is required for such a mechanical leveler. These levelers tend to be the most expensive to service and to maintain over their life.

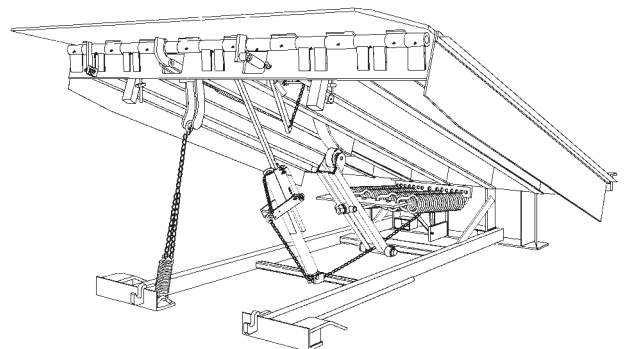

Mechanical Dock Leveler

Dock Levelers

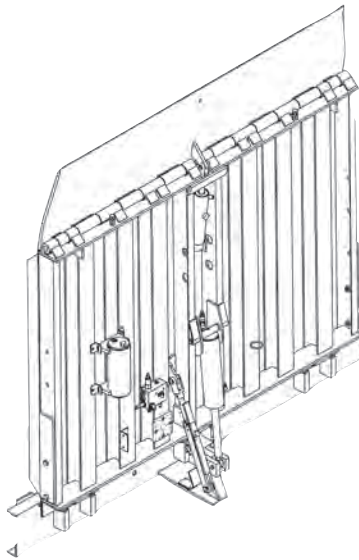

Vertical Leveler

Vertical Leveler A vertical leveler is exactly what the name implies - a dock leveler that is stored in a vertical position. Why is this desirable? This allows you to store the leveler inside the building and to close your dock door on concrete, instead of across the leveler, as is the case of a pit leveler. This should allow better environmental control in your building. These vertical levelers are often used in food service applications or areas where wash down is an issue. Vertical levelers are typically pit or shelf-mounted and hydraulically operated.

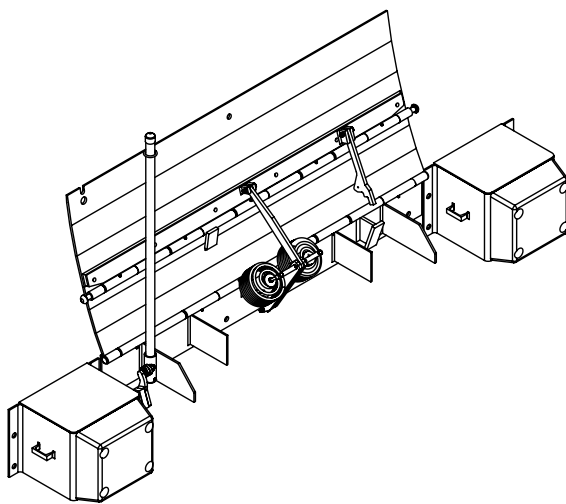

Edge of Dock Leveler

Edge of Dock (EOD) Leveler This is a simple device that is usually mechanically operated but may be pneumatically or hydraulically operated. It is often found mounted on the exterior wall of a building with an integral bumper set but may also be pit mounted. The EOD has a limited vertical operating range and is geared toward applications where the transport vehicle bed is at, or very near, the floor level of the building (dock level). These units are generally inexpensive when compared to a pit or vertical dock leveler but may be considered an upgrade from portable dock boards as they are fixed to the dock face and have some form of lift assistance (mechanical, air or hydraulic). A recommended normal working range of an EOD is typically +/- 3 inches.

Dock Levelers

Specifying the Right Dock Leveler

Because of its wider range of operation, pit style dock levelers are always the best choice to accommodate a wide range of trailer bed heights. You should specify the EOD dock leveler only if the facility operates within the narrow applications suitable for the EOD.

Dock levelers have long lives, because they contribute significantly to facility efficiency, it is very important to accurately specify each of the following dock leveler characteristics:

- Length
- Width
- Lip projection
- Activation system
- Environmental capability
- Load capacity

Length

The length of the dock leveler significantly determines the dock leveler slope. This slope has to be less than the maximum grade capability of the loading equipment. The required length of the dock leveler is based on the maximum height differential between the loading platform and the expected truck beds, e.i. the greater the differential the longer the leveler needs to be.

Width

Most manufacturers offer three standard widths in mechanical and hydraulic dock levelers: 6' wide, 6.5' wide and 7' wide, nominal. The 6' wide units are the most common and can accommodate the majority of applications.

Lip Projection

The dock leveler lip must extend at least 4 in. into the truck per ANSI MH30.1 (Figure 54). A standard lip is 16 in, which projects 12 in. in front of the dock bumpers. Longer lips may be needed to accommodate the special rear step and rear door configurations on some trailers. The step of a refrigerated trailer may require a lip projection that is 14 in. or longer past the bumpers.

Activation System

Push button activation is the most ergonomic and safest type of dock leveler activation system. Manual or spring counterbalance activation should be used only when electrical power is not available. Push button–operated dock levelers may be less expensive over the long term as they require less service.

Environmental Capability

On inside/outside docks at temperature-controlled facilities, use perimeter weather seals to help prevent outside air from entering the building. At refrigerated facilities, the underside of the dock leveler ramp should be insulated. Condensation on the underside of the ramp causes corrosion and structural problems. Expanded foam insulation helps prevent the warmer outside air from condensing on the underside of the ramp. Insulation also saves energy by minimizing the loss of refrigerated air.

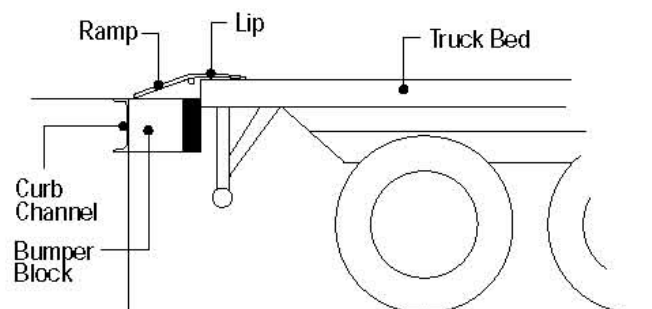

Dock Levelers

Load Capacity

Choosing the right load capacity for a dock leveler can greatly extend the dock leveler's life. The dock leveler's load capacity is dependent upon the gross vehicle weight (GVW) of the forklift using the dock levelers.

The GVW includes the weight of the forklift plus the weight of the maximum anticipated load. For electric forklifts the GVW also must include the weight of the battery.

As a guideline, the empty weight of propane and gasoline powered forklifts is within the range of 170-210% of its load capacity. Electric forklifts weigh about 1100 lbs. to 1800 lbs. more because of the batteries.

To determine the dock leveler's load capacity, f

Conditions Affecting Load Capacity

- More than eight trucks per day will be served at the dock position.
- Forklifts will drive onto the dock leveler at an angle rather than straight ahead.
- Three-wheeled forklifts will be used The expected forklift speeds will exceed 4 mph.
- The forklifts will be outfitted with front end attachments or fork side-shifters.

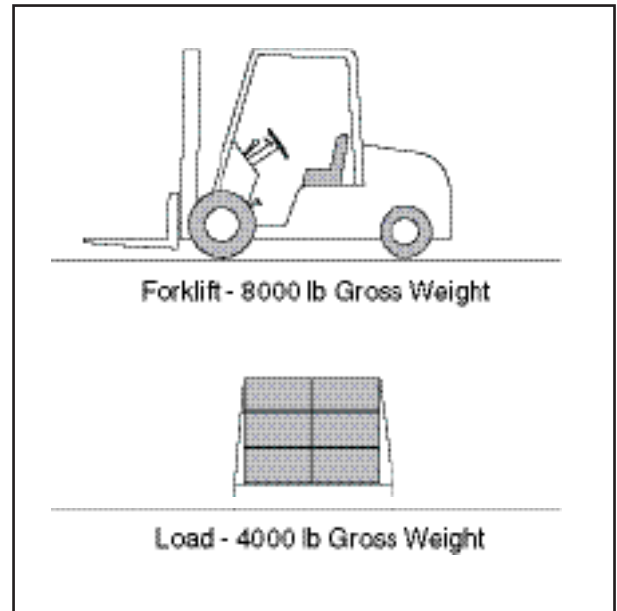

$$\text{GVW} = \text{Weight of forklift} + \text{Weight of maximum load}$$
$$\text{Load Capacity} = \text{GVW} \times 2.5$$

Example: 12,000 lb forklift gross weight + 6,000 lb gross load =
18,000 lb \times 2.5 = 45,000 lb load capacity

Vehicle Restraints

What kinds of vehicle restraints are there?

There are many different kinds of restraints. The most basic type is a “wheel chock” which can be utilized with or without a light communication package. Vehicle restraint systems can be manually or automatically activated. Vehicle restraints restrict movement of a transport vehicle by engaging the rear impact guard (RIG) or actual wheels of the transport vehicle. These restraints are typically mounted to/in the dock wall or drive immediately in front of the dock and typically include special designs that are unique to an individual manufacturer as well as have unique installation characteristics based on an individual manufacturer.

Basic Wheel Chock: A wheel chock can be a simple block of wood, form fitted rubber/laminate wedge chock or constructed of plastic or metal alloy. A wheel chock is manually placed in front of one or more of the trailers wheels in an attempt to restrict the trailers movement during the loading/unloading process.

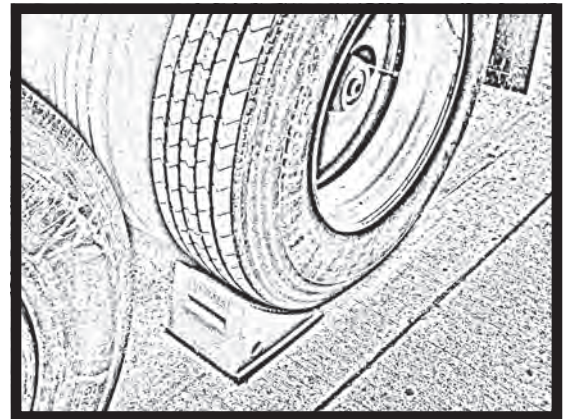

Light Communication Package: A light communication package can stand alone, be combined with a simple wheel chock or integrated with a vehicle restraint system. A common system would include an interior and exterior “red” and “green” lighting system designed to enhance the communication between dock operating personnel and transport vehicle driver. A set of signs are frequently added to indicate when it is safe to enter the trailer or pull away from the dock area. The lighting sequence can be manually or automatically activated.

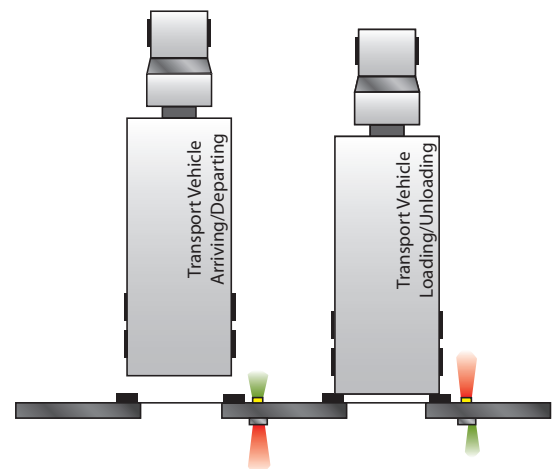

Vehicle Restraints

Rear Impact Guard (RIG) Type:

This is by far the most common type of vehicle restraint. It is designed to engage the RIG bar common to most transport vehicles. It does this by either blocking the bar (rotating hook) or forming a vertical obstruction, preventing the vehicle from moving away from the dock until the restraint is released by the dock operator. These restraints are typically mounted to either the dock wall or to the drive immediately in front of the dock, but can also be recessed in the building structure under the dock pit as well.

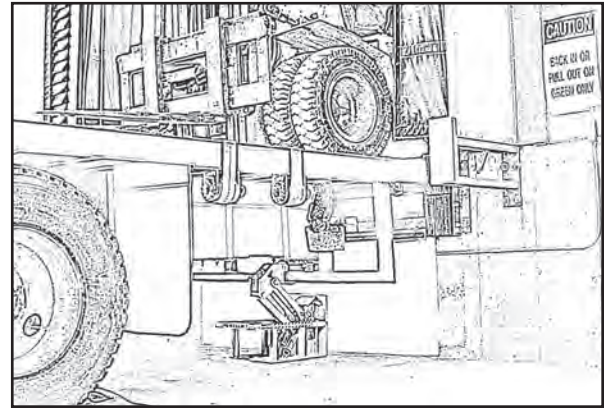

Wheel Engaging Type: This type of restraint acts by engaging one or more of the tires of the transport vehicle. Wheel engaging restraints are frequently used in applications where the transport vehicles being serviced do not have RIG bars or RIG bar is obstructed, such as lift gate trailers or small city delivery vehicles. These systems are typically surface or recess mounted to the driveway for ease of installation and to aid in vehicle alignment. Automatic and manually positioned systems are available.

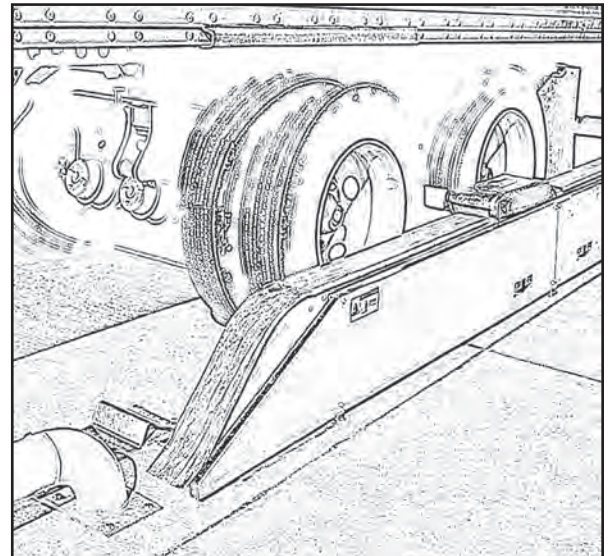

Vehicle Restraints

Dock Mount: Device is affixed to the foundation wall via concrete anchors and/or embedded steel plates. Installation brackets are frequently required to secure the restraint for specific dock configurations.

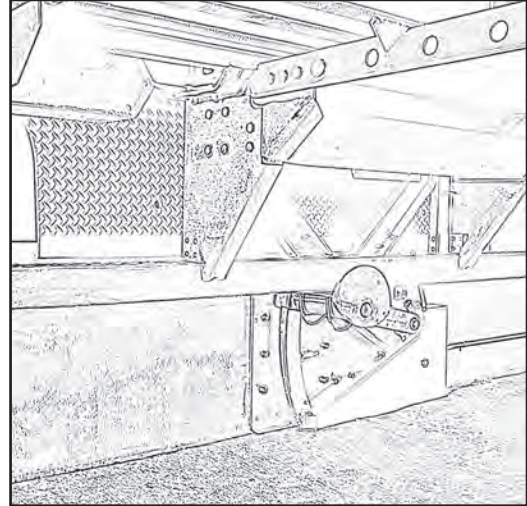

Interior Pit Mount: Device is recessed behind the foundation wall or part of a “deep pit” stand.



Driveway Mount: Device is affixed to drive surface or recessed into the driveway approach.



Dock Seals and Shelters

Selecting Seals and Shelters

Seals and shelters close the space between the trailer and the building. They help maintain a controlled atmosphere on the dock and the protect the cargo. Seals and shelters also improve productivity, energy efficiency, safety and security.

Sealing systems have many benefits:

- Energy savings – The system can quickly pay for itself in reduced heating and cooling costs by maintaining the building's interior temperature.
- Safety and productivity – Eliminates dangerous precipitation from the loading areas. Worker productivity correlates to the workplace environment and its safety.
- Freight protection – Protects freight against harmful weather and minimizes entry of vermin.
- Security – Prevents product theft and unauthorized entry.
- Storage – Docked trailers become secure, climate controlled extensions of the building.

There are two types of sealing systems:

- Compression foam dock seals – The seals are made of foam covered with fabric. They are mounted to the wall at the loading door and seal against the back of the truck.
- Dock shelters – Dock shelters have a rigid or flexible frame equipped with curtains. The frame is installed to the building wall. The curtains extend and seal against the wall and the rear of the truck

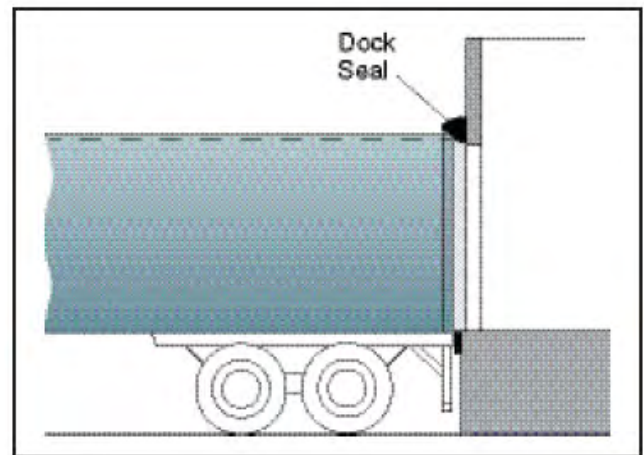

Dock Seal

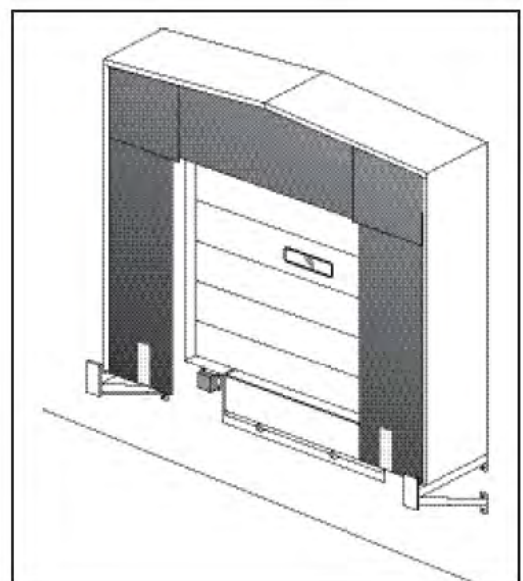

Dock Shelter

Common Types of Dock Seals

What kinds of dock seals and shelters are there?

There are many different kinds of dock seals and shelters.

Dock Seal: In general dock seals are constructed of foam covered fabric sized to compress and seal against the rear of a trailer. A dock seal is typically applied with smaller door openings and can achieve up to 90% efficiency when controlling air flow at the dock.

Fixed Head Dock Seal

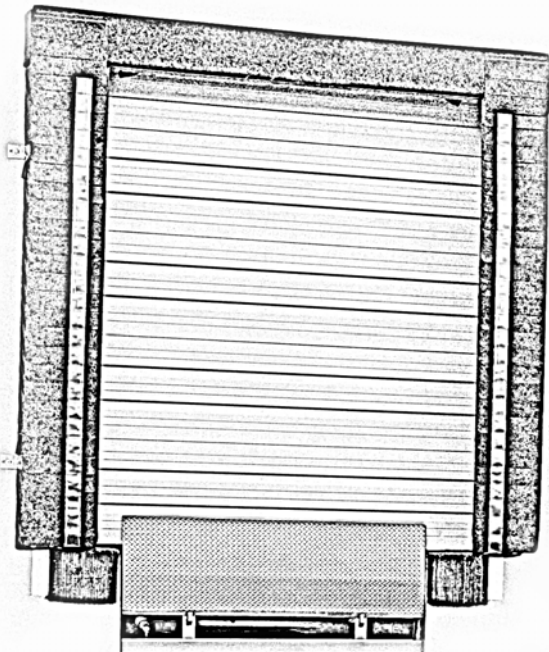

Description:

This type of dock seal incorporates a foam filled side and head pad. It is one of the more popular and effective dock seals when the application calls for common dock parameters and uniform trucks at the dock.

Head Curtain Dock Seal

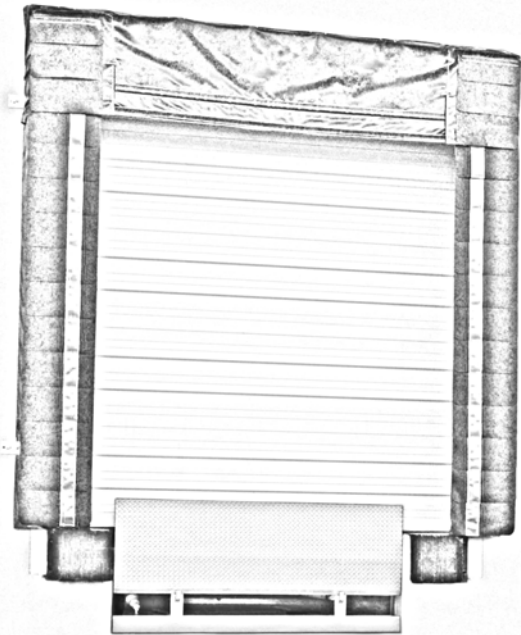

Description:

This type of dock seal incorporates foam filled side pads and is popular and effective in applications where a wide variety of trailer heights are experienced and/or a wide range of facility door heights are present. It is common for the unit to have either a fixed or adjustable fabric head curtain specific in length to service known fleets of trailers. Optional foam filled curtains can help seal the trailer and provide greater energy efficiency.

Common Types of Dock Seals

Adjustable Head Pad

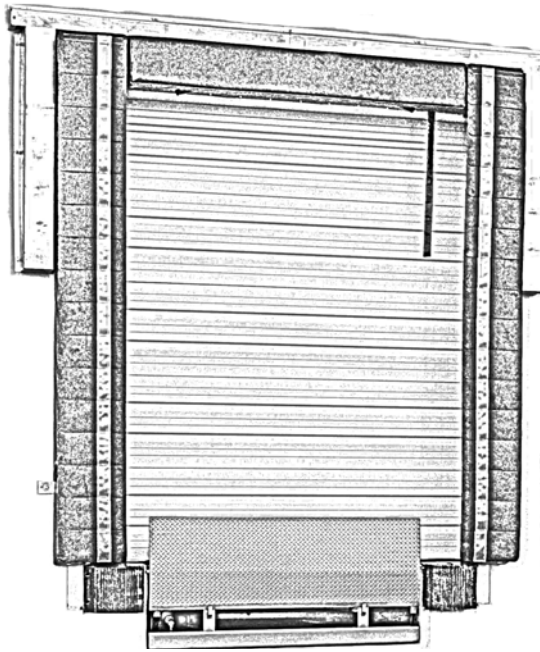

Description:

This type of seal was once popular years ago but has since lessened in popularity due to the required moving parts and cost of ownership versus other acceptable models. Similar to the “Head Curtain” seal, this product can service varying height vehicles at a wide range of door heights. Similar to the “Fixed Head” dock seal it incorporates a foam pad proving a higher level of energy efficiency.

“L” Shaped Dock Seal

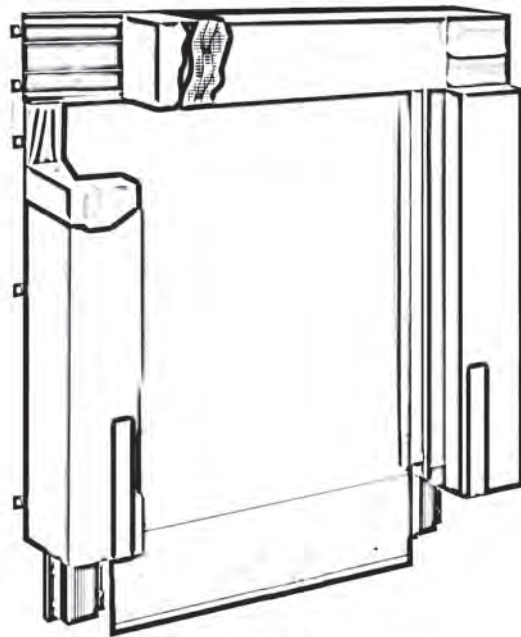

Description:

The name of this dock seal originates from its “L” shaped side pads. The shape of the seal and the increased projection makes it ideally suited to work on wider door openings. The shape and projection are designed to seal the sides of the trailer rather than the back enabling wider and improved access to the rear of the trailer. The “L” shaped seal can have either a “fixed head” or “curtain” header.

Common Types of Dock Seals

Inflatable Seal



Description:

The inflatable seal incorporates an external blower/fan assembly and inflates after a trailer is positioned at the dock. Since the unit is electrical in nature, it is common to interlock these units with the dock equipment or overhead door so to activate only when truck is actively serviced. A variety of shapes and sizes are available.

Common Types of Dock Shelters

Dock Shelter: General dock shelters are constructed of wood or metal frame and can be rigid or flexible. Fabric and/or fiberglass generally attached to the outer surface and fabric curtains attach to the face of the unit and seal the sides and top of the transport vehicle as it backs through the product. A dock shelter is typically applied to larger door openings where truck configurations may vary and achieve up to 70% efficiency when controlling air flow at the dock.

Rigid Dock Shelter

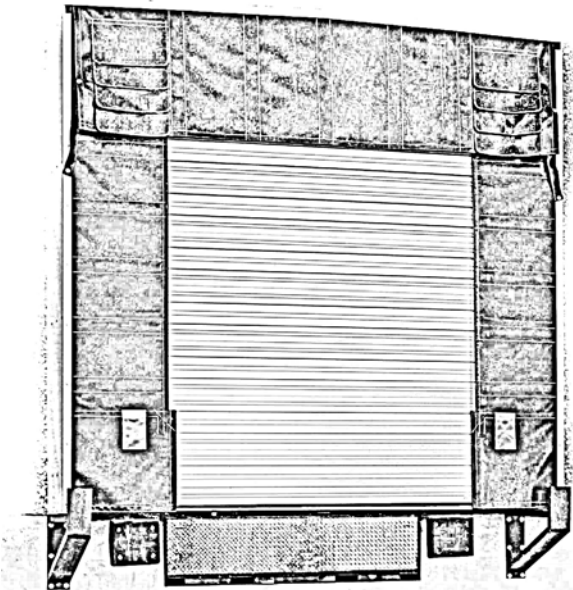

Description:

The most popular shelter, the “Rigid Dock Shelter” is widely accepted for oversized doors, a variety of trailer heights are present and where full access to the rear of the trailer is important. Rigid sides and head frames are supported by steel supports and typically are constructed with either fiberglass sides or a “light emitting” fabric to illuminate the dock area during daytime loading. The head member also acts as a “canopy” and can even support a snow load reducing the need for expensive architectural canopies popular with dock seals.

Flexible Shelters

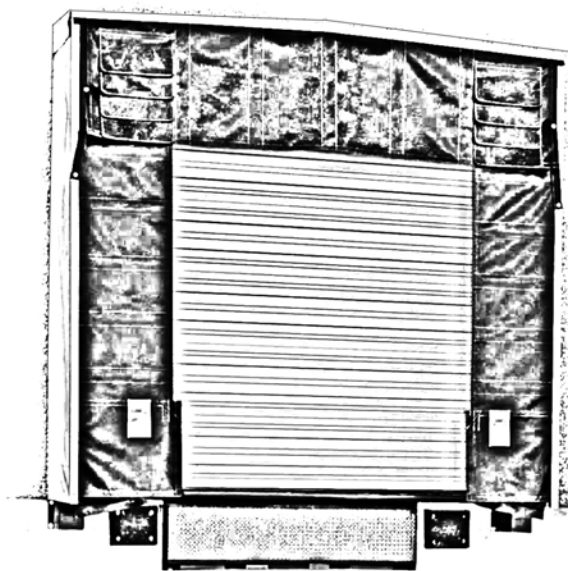

Description:

This shelter fits on oversized doors and services a wide variety of trailer types and sizes while providing wide access to the back of the trailer. The shelter is either gravity or spring biased to hold tight to the trailer, yet yield should an off-center trailer approach and impact the sides. The “flexible nature” of the product is designed to reduce building and shelter damage should an approaching truck impact the unit.

Common Types of Dock Shelters

Combo Shelter or Soft Sided Shelter

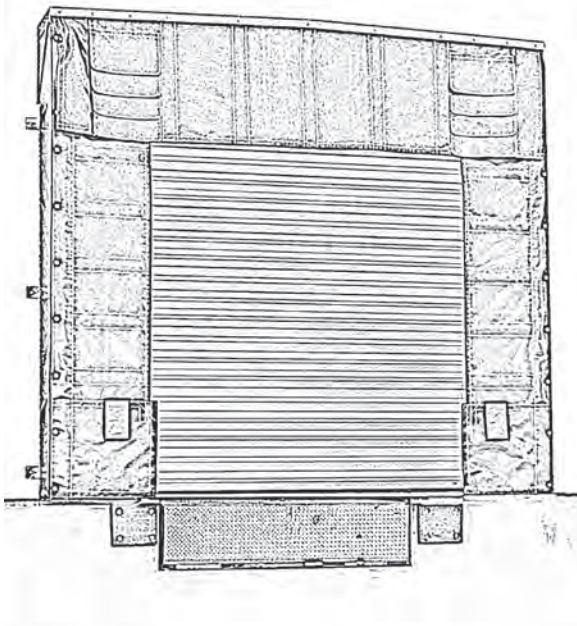

Description:

This shelter combines the flexibility of a seal with full vehicle access of a shelter. The sides are constructed similar to a foam filled dock seal, while the head member is constructed similar to a rigid frame dock shelter. The units seal the sides of the trailer and provide a higher efficiency rating than a conventional rigid shelter. It also provides a degree of protection for the building and units due to its “flexible” side member construction.

Shelter Weather Canopy

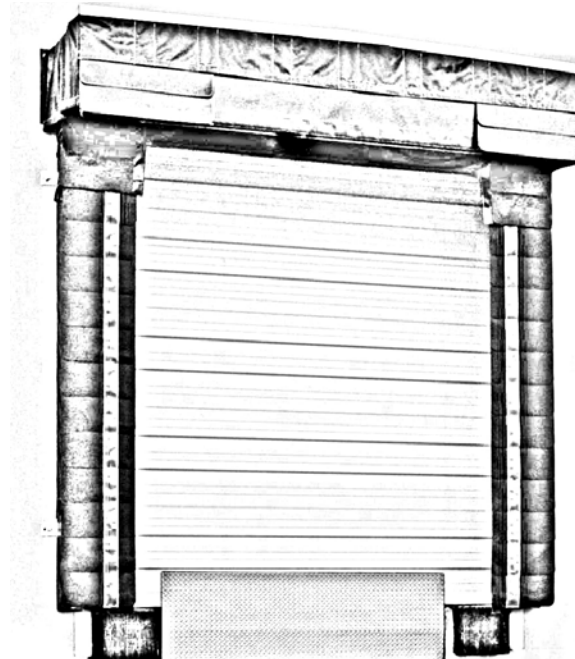

Description:

Several versions of the “Weather Canopy” are available on the market. The head member assembly can be combined with a “Shelter” or “Seal” to provide a higher degree of rain protection than conventional rigid shelter tops and seal curtains. It is also ideally suited where application dictates a “decline” dock and where trailer heights are fairly consistent.

Common Types of Dock Shelters

Inflatable Shelter

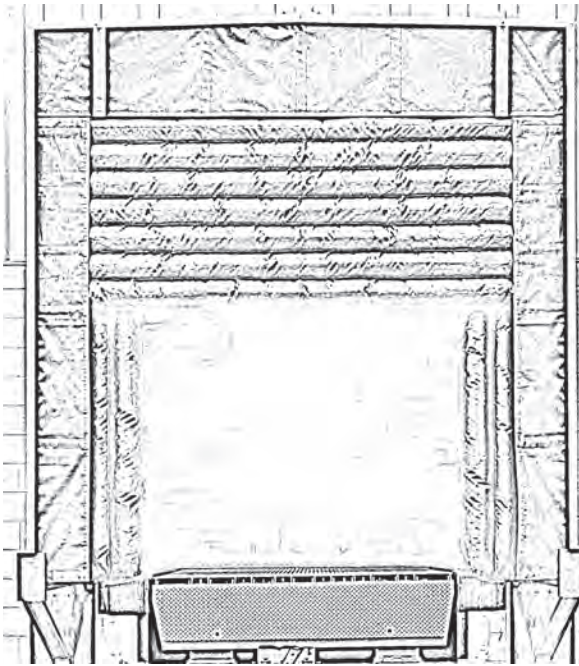

Description:

Similar to other shelter products this unit seals the sides of the trailer permitting full access to the rear of the trailer. An integral blower assembly inflates the side members. Since the unit is electrical in nature, it is common to interlock these units with the dock equipment or overhead door so to activate only when truck is actively serviced. A variety of shapes and sizes are available.

Mechanical Rail Shelter

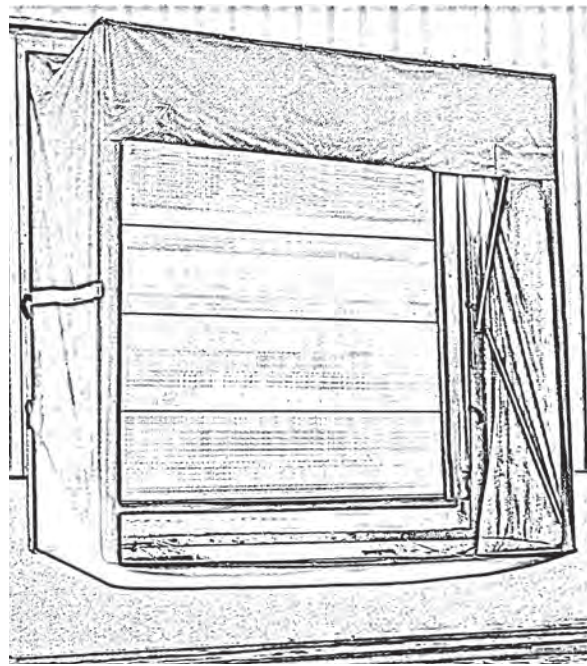

Description:

A basic shelter that is spring loaded or counterweighted and designed to extend once the rail car is positioned at the opening. The unit is available in an array of sizes given the doors in a rail area are often oversized to allow flexibility to the positioning of a heavy rail car. These shelters can be three sided or four sided to reduce air flow at the opening. It is good practice to combine the shelter with an overhead “canopy” to protect the unit in the stored position.

Common Types of Dock Shelters

Inflatable Rail Shelter

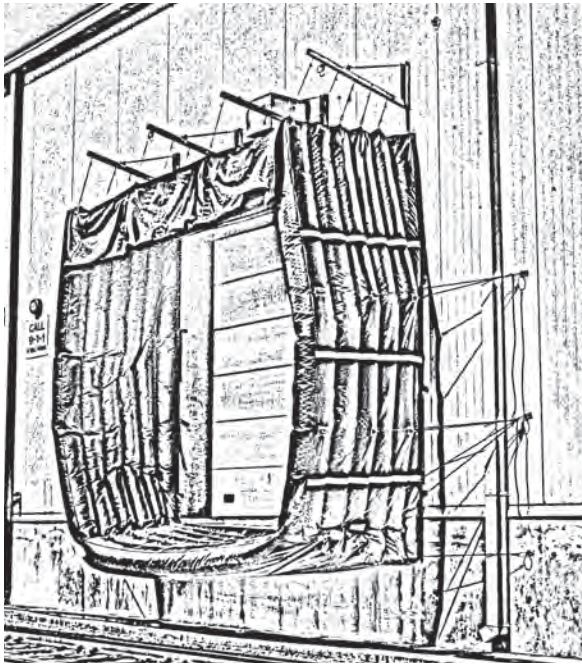

Description:

Becoming increasingly popular at rail sidings is the “Inflatable Rail Shelter.” The unit incorporates an external blower(s) and is designed to extend against the rail car once it is positioned at the rail siding. The inflatable bag adheres to the contours of the rail car providing a better seal than a mechanical unit. An optional fourth sided draft extension can also help reduce air flow at the dock. Since the unit is electrical in nature, it is common to interlock these units with the dock equipment or overhead door so to activate only when rail car is actively serviced. A variety of shapes and sizes are available.

Metal Hoods

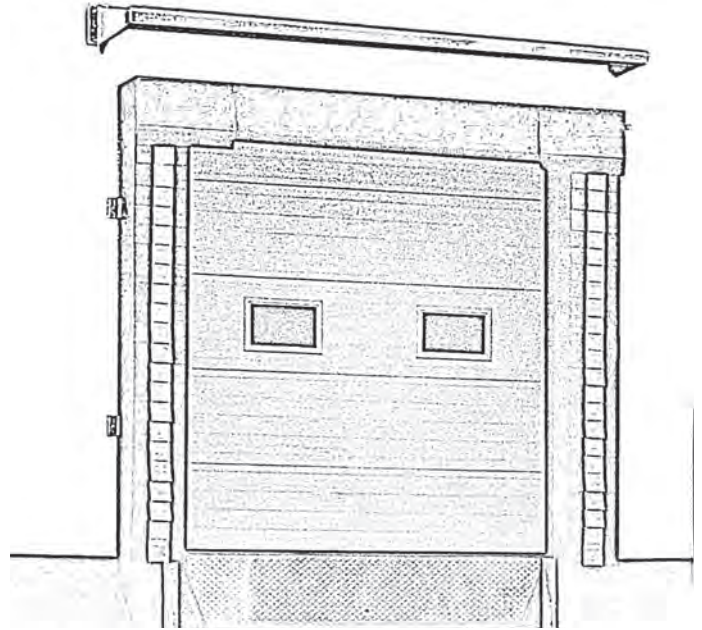

Description:

Many facilities design architectural type canopies extending four (4) feet or more over the dock area. The combination of a canopy and shelter or seal provides the most protection against inclement weather. Alternatively, a manufactured canopy or hood is available from most loading dock equipment manufacturers and can be an economical alternative at the dock area. It is highly recommended you consider some type of canopy to augment curtain style seals, inflatable seals, flexible shelters and all rail products, especially in northern climates.

Dock Seals and Shelters

Facility Owner Considerations:

Selecting the optimal product for a particular application is a trade-off of compromised considerations, which will direct you to the best solution for the majority of the fleet. To properly size and select a specific product for a user receiving a high range of trailer variation, it may be important to consider the common 80% of the fleet. A trained professional will consider many factors when recommending a product such as:

- **Door Sizes**
- **Building Structure**
- **Material Handling**
- **Cargo**
- **Truck Types/Sizes**

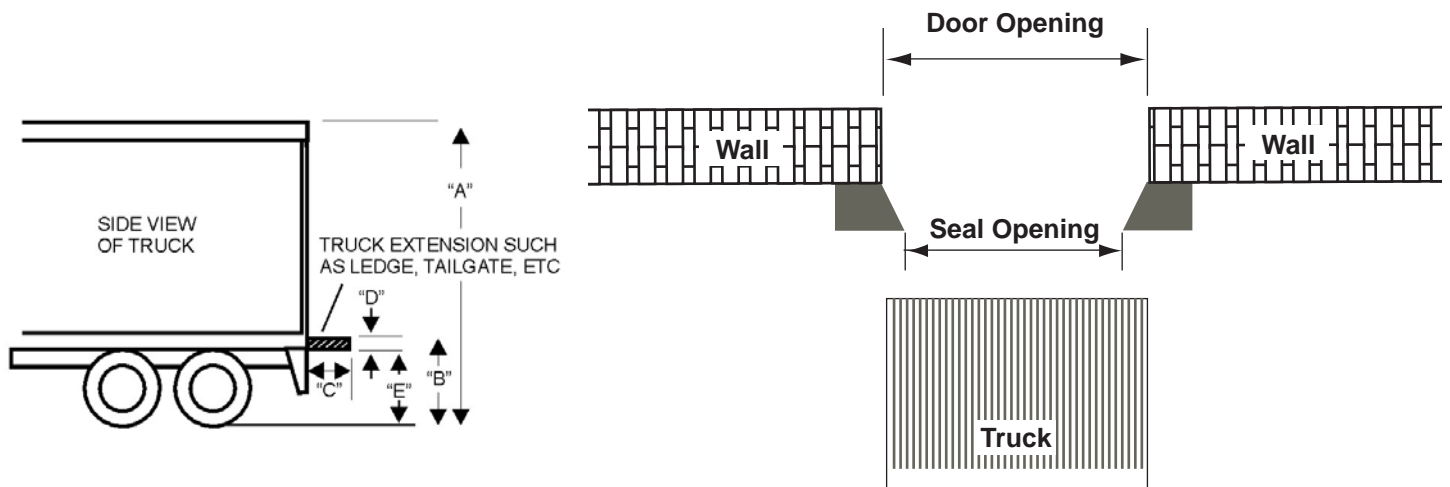

Fabric Types:

The durability of dock seals and shelters can be enhanced by the selection of quality fabric covers. Traditional fabrics were hypalons, vinyls and neoprene. Over time, performance fabrics offering premier tear and abrasion characteristics as well as UV inhibitors and fabric with fire retardant qualities have replaced the hypalon and neoprene products. The weight of a particular fabric is stated as “oz” per yard. Tear and abrasion data can be requested from manufacturer as a basis of comparison.



More Information

How do I find out more?

This reference document was created by the member companies of the Loading Dock Equipment Manufacturer's, an industry group association of MHI.

You can contact the Loading Dock Equipment Manufacturer's website at www.MHI.org/LODEM

DISCLAIMER OF LIABILITY. LODEM, the Material Handling Industry, MHI, and their members assume no responsibility and disclaim all liability of any kind, however arising, as a result of acceptance or use or alleged use of this Guide. User specifically understands and agrees that LODEM, the Material Handling Industry, MHI, their members, their officers, agents, and employees shall not be liable under any legal theory of any kind for any action or failure to act with respect to the proper selection of a material handling system as well as matters such as the service for which it will be used, the frequency of its use, matching its speed with manufacturing needs, budget or any other activity covered by This Guide. Any use of this information must be determined by the user to be in accordance with applicable federal, state, and local laws and regulations.

DISCLAIMER OF WARRANTY. LODEM, the Material Handling Industry, MHI, and their members make NO WARRANTIES of any kind, express, implied, or statutory, in connection with the information in this Guide and SPECIFICALLY DISCLAIM ALL IMPLIED WARRANTIES OF MERCHANTABILITY AND OF FITNESS FOR PARTICULAR PURPOSE.

INDEMNIFICATION. By referring to or otherwise employing This Guide, the user agrees to defend, protect, indemnify, and hold LODEM, the Material Handling Industry, MHI, their members, their officers, agents, and employees harmless from and against all claims, losses, expenses, damages, and liabilities, direct, incidental, or consequential, arising from acceptance or use or alleged use of this Guide, including loss of profits and reasonable attorneys' fees which may arise out of the acceptance or use or alleged use of this Guide. The intent of this provision and of the user is to absolve and protect LODEM, the Material Handling Industry, MHI, their members, their officers, agents, and employees from any and all loss relating in any way to this Guide, including those resulting from the user's own negligence.

Notes

LODEM

LOADING DOCK EQUIPMENT MANUFACTURERS

Loading Dock Equipment Manufacturers Product Section of
The Material Handling Industry, MHI
8720 Red Oak Boulevard, Suite 201
Charlotte, NC 28217-3992
Telephone: (704) 676-1190
Fax: (704) 679-1199
www.MHI.org/LODEM

LODEM
LOADING DOCK EQUIPMENT MANUFACTURERS